



HAVELLS

HAVELLS LIGHTING LLC

# PRODUCT INFORMATION



## Tenon

### TENON ANGULAR WALL MOUNT WITH 2 3/8" TENON

Havells Lighting provides a comprehensive range of brackets and accessories to complement your lighting projects. We maintain the same high standards of quality and durability for our accessories as we do for our lighting products.

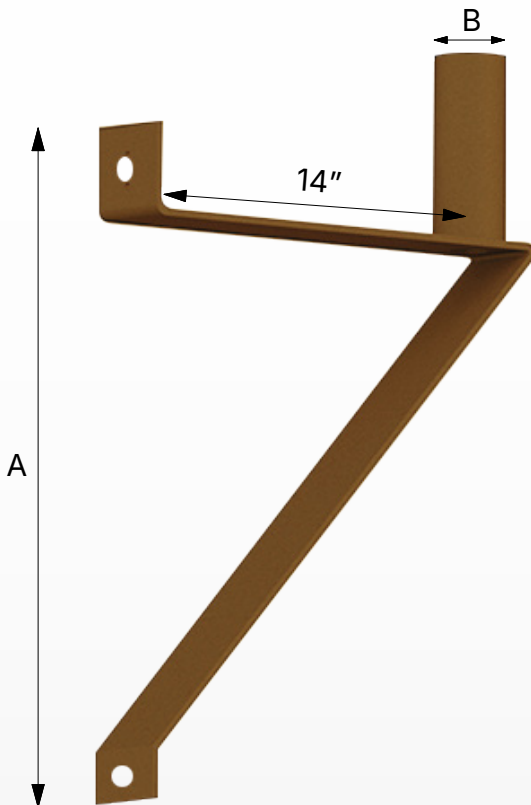

## Technical Data

Product Code	HL-TN-SAWMT
Product Name	Steel Angular Wall Mount With 2 3/8" Tenon
Construction	Steel
Finish	Galvanized
Pipe Thickness	11 Gauge
Pack Quantity	04

## Dimension and Weight

A	20 in
B	2.375 in
Weight	9.5 lb